

L-MOUNT SERIES (L21/L22/L44/L64)

Features

- Marking of mounts with military designations available on special order
- Aluminum construction
- Axial to radial stiffness of 4:1
- For base mounting only
- Fail safe construction

Benefits

- Isolation performance maintained in attitudes up to 10° from the horizontal
- Low ratio of horizontal and vertical stiffness which holds transmissibility in rocking modes to unusually low magnitudes

Load Range

- L21/L22 = 7 load ranges from .35 - 4 lbs. per mount
- L44 = 7 load ratings from .25 - 10 lbs. per mount
- L64 = 7 load ratings from 2.0 - 40 lbs. per mount

Low-frequency, highly damped mounts for a high level of vibration isolation.



Barry L-Mounts increase equipment reliability and extend component life by providing isolation for frequencies as low as 10 Hertz and exhibiting low transmissibility at resonance (below 2.5) with .60" double amplitude vibratory input.

Applications

- Avionic equipment in propeller driven aircraft
- Sensitive instrumentation and medical equipment
- Stationary applications where cost effective, low frequency isolation is required

NATURAL FREQUENCY	7-10 Hertz
TRANSMISSIBILITY AT RESONANCE	2.5
RESILIENT ELEMENT	Friction damped spring
STANDARD MATERIALS	Aluminum
WEIGHT	L21 = .031 lbs. L22 = .031 lbs. L44 = .098 lbs. L64 = .226 lbs.

Environmental Data

- Operating temperature ranges of -67°F to +250°F (-55°C to +120°C).
- Meets vibration and shock requirements of MIL-C-172C.
- L44 and L64 isolators are known as "MS" (Military Standard) mounts and appear on QPL's.

L Mount Series (L21/L22)

Dimensions & Performance Characteristics

L21 Dimensional Drawing

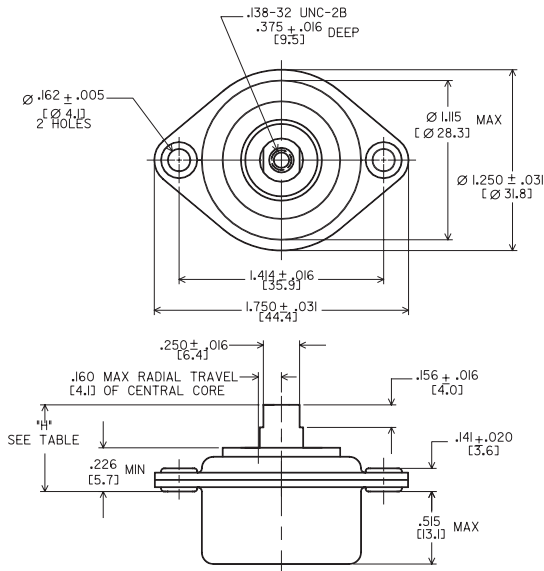

L22 Dimensional Drawing

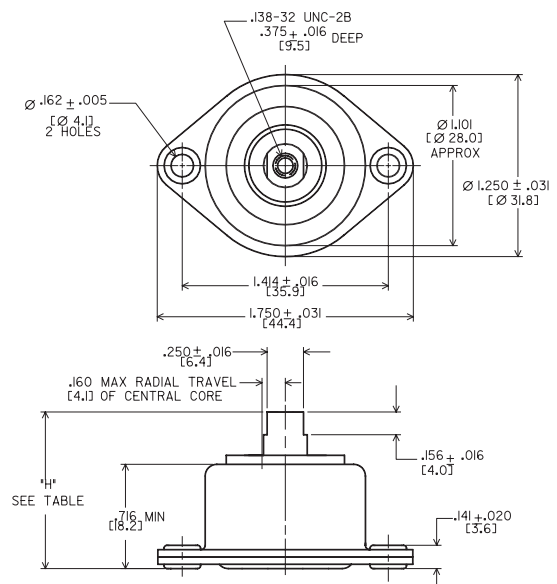

L21 & L22 Load vs. Natural Frequency

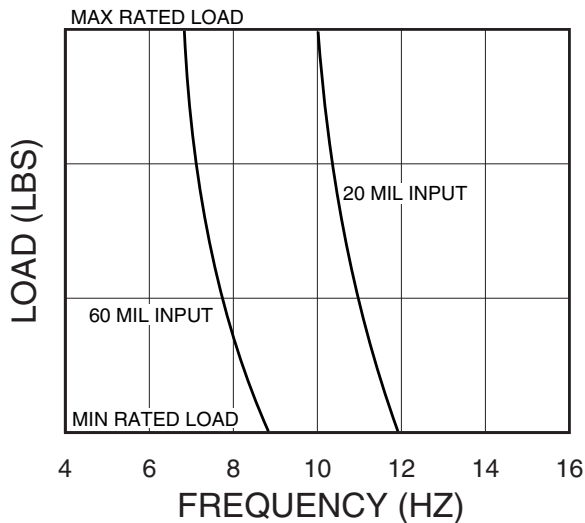

L21-BA MOUNT

HEIGHT OF ALUMINUM CORE (Inches) ("H")

Compressed .219 (min.)

Under min. load 0.50 (approx.)

Extended .703 (max.)

L22-BA MOUNT

HEIGHT OF ALUMINUM CORE (Inches) ("H")

Compressed .719 (min.)

Under min. load 1.00 (approx.)

Extended 1.172 (max.)



Barry Controls

40 Guest Street • Brighton, MA 02135-9105 • (617) 787-1555 • Fax (617) 787-7807

Dimensions and data are subject to change without notice.

For technical, design, or application assistance, call toll free:

1-800-BARRY MA

L Mount Series (L44)

Dimensions & Performance Characteristics

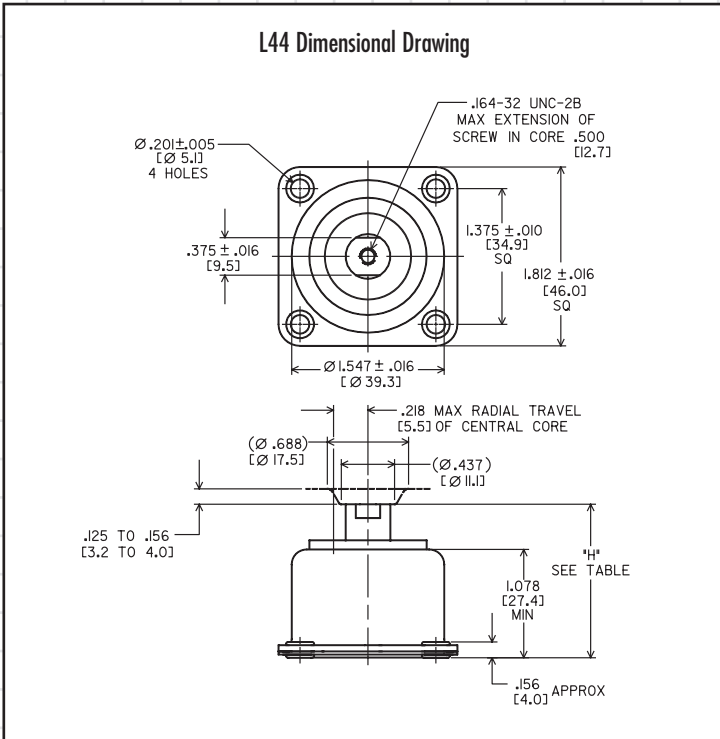

L44 MOUNT	L44-AA	L44-BA
HEIGHT OF ALUMINUM CORE (Inches) ("H")		
Compressed (min.)	.975	1.131
Under min. load (approx.)	1.375	1.562
Extended (max.)	1.632	1.788

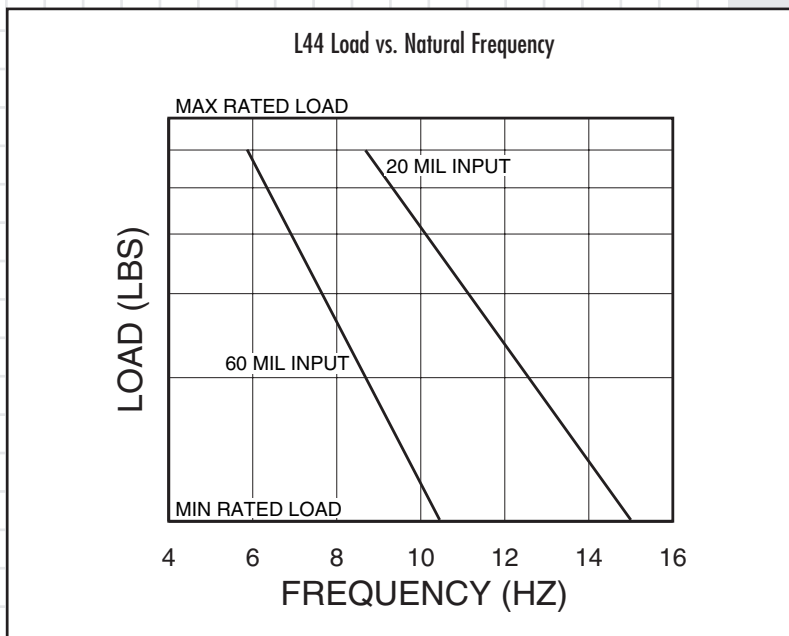

Barry Controls
40 Guest Street • Brighton, MA 02135-9105 • (617) 787-1555 • Fax (617) 787-7807

Dimensions and data are subject to change without notice.

For technical, design, or application assistance, call toll free:

1-800-BARRY MA

L Mount Series (L64)

Dimensions & Performance Characteristics

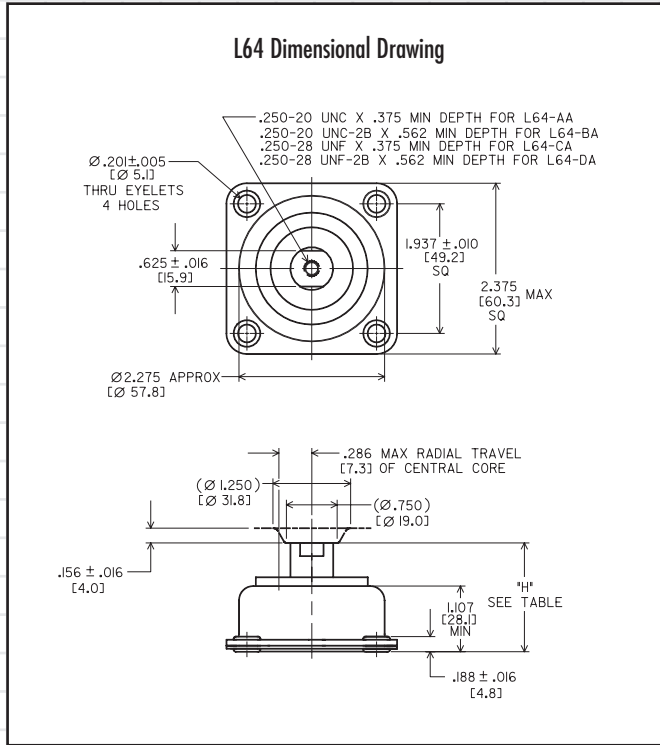

L64 MOUNT	L64-AA+CA	L64-BA+DA
HEIGHT OF ALUMINUM CORE (Inches) ("H")		
Compressed (min.)	.982	1.148
Under min. load (approx.)	1.406	1.562
Extended (max.)	1.540	1.706

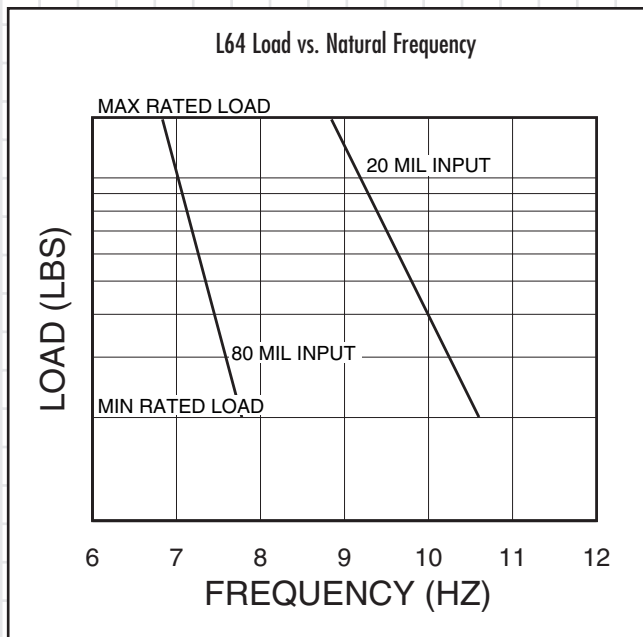

Barry Controls
 40 Guest Street • Brighton, MA 02135-9105 • (617) 787-1555 • Fax (617) 787-7807

Dimensions and data are subject to change without notice.

For technical, design, or application assistance, call toll free:

1-800-BARRY MA

L Mount Series (L21/L22/L44/L64)

Load Range & MS Specifications

LOAD RANGES (L21/L22/L44 SERIES)	
Part #	Static Load/Isolator
L21 & L22-BA-0.5	0.38-0.54 lbs.
L21 & L22-BA-0.7	0.44-0.75 lbs.
L21 & L22-BA-1.0	0.56-1.00 lbs.
L21 & L22-BA-1.3	0.88-1.30 lbs.
L21 & L22-BA-2.0	1.20-2.00 lbs.
L21 & L22-BA-3.0	1.70-3.00 lbs.
L21 & L22-BA-4.0	2.50-4.00 lbs.
L44-AA-5 & BA-5	0.25-.50 lbs.
L44-AA-1 & BA-1	0.50-1.00 lbs.
L44-AA-2 & BA-2	1.0-2.0 lbs.
L44-AA-3 & BA-3	1.50-3.0 lbs.
L44-AA-4 & BA-4	2.0-4.0 lbs.
L44-AA-5 & BA-5	2.5-5.0 lbs.
L44-AA-10 & BA-10	5.0-10.0 lbs.
L64-AA-4, BA-4, CA-4 & DA-4	2.0-4.0 lbs.
L64-AA-6, BA-6, CA-6 & DA-6	3.0-6.0 lbs.
L64-AA-10, BA-10, CA-10 & DA-10	4.5-10.0 lbs.
L64-AA-12, BA-12, CA-12 & DA-12	6.25-12.5 lbs.
L64-AA-16, BA-16, CA-16 & DA-16	9.0-16.0 lbs.
L64-AA-20, BA-20, CA-20 & DA-20	10.0-20.0 lbs.
L64-AA-40, BA-40, CA-40 & DA-40	20.0-40.0 lbs.

Dimensions and data are subject to change without notice.

For technical, design, or application assistance, call toll free:

1-800-BARRY MA



Barry Controls
40 Guest Street • Brighton, MA 02135-9105 • (617) 787-1555 • Fax (617) 787-7807

L64 Series Load Range, "H" Dimension and MS Designation

**Military designation load ranges are tighter than Barry Standard*

Part #	*Load Range (lbs.)	*Military Designation	"H"
L64-AA-4	1.91-2.59	MS91418-2BAL	1.405
L64-BA-4	1.91-2.59	MS91418-2BAS	1.571
L64-CA-4	1.91-2.59	MS91418-2BAD	1.405
L64-DA-4	1.91-2.59	MS91418-2BAH	1.571
L64-AA-4	2.0-4.5	MS91418-2AAL	1.399
L64-BA-4	2.0-4.5	MS91418-2AAS	1.565
L64-CA-4	2.0-4.5	MS91527-2AAD	1.399
L64-DA-4	2.0-4.5	MS91527-2AAH	1.565
L64-AA-4	2.55-3.45	MS91418-2BBL	1.352
L64-BA-4	2.55-3.45	MS91418-2BBS	1.518
L64-CA-4	2.55-3.45	MS91527-2BBD	1.352
L64-DA-4	2.55-3.45	MS91527-2BBH	1.518
L64-AA-4	3.0-5.0	MS91418-2ABL	1.390
L64-BA-4	3.0-5.0	MS91418-2ABS	1.556
L64-CA-4	3.0-5.0	MS91527-2ABD	1.390
L64-DA-4	3.0-5.0	MS91527-2ABH	1.556
L64-AA-4	2.55-3.45	MS91418-2BBL	1.352
L64-BA-4	2.55-3.45	MS91418-2BBS	1.518
L64-CA-4	2.55-3.45	MS91527-2BBD	1.352
L64-DA-4	2.55-3.45	MS91527-2BBH	1.518
L64-AA-4	3.40-4.60	MS91418-2BCL	1.365
L64-BA-4	3.40-4.60	MS91418-2BCS	1.561
L64-CA-4	3.40-4.60	MS91527-2BCD	1.365
L64-DA-4	3.40-4.60	MS91527-2BCH	1.561
L64-AA-4	4.67-6.33	MS91418-2BDL	1.392
L64-BA-4	4.67-6.33	MS91418-2BDS	1.558
L64-CA-4	4.67-6.33	MS91527-2BDD	1.392
L64-DA-4	4.67-6.33	MS91527-2BDH	1.558
L64-AA-10	4.5-10.0	MS91418-2ACL	1.395
L64-BA-10	4.5-10.0	MS91418-2ACS	1.561
L64-CA-10	4.5-10.0	MS91527-2ACD	1.395
L64-DA-10	4.5-10.0	MS91527-2ACH	1.561
L64-AA-10	4.67-6.33	MS91418-2BDL	1.392
L64-BA-10	4.67-6.33	MS91418-2BDS	1.558
L64-CA-10	4.67-6.33	MS91527-2BDD	1.392
L64-DA-10	4.67-6.33	MS91527-2BDH	1.558
L64-AA-10	6.37-8.63	MS91418-2BEL	1.362
L64-BA-10	6.37-8.63	MS91418-2BES	1.528
L64-CA-10	6.37-8.63	MS91527-2BED	1.362
L64-DA-10	6.37-8.63	MS91527-2BEH	1.528
L64-AA-12	6.25-12.50	MS91418-2ADL	1.372
L64-BA-12	6.25-12.50	MS91418-2ADS	1.538
L64-CA-12	6.25-12.50	MS91527-2ADD	1.372
L64-DA-12	6.25-12.50	MS91527-2ADH	1.538
L64-AA-12	8.50-11.50	MS91418-2BFL	1.339
L64-BA-12	8.50-11.50	MS91418-2BFS	1.505
L64-CA-12	8.50-11.50	MS91527-2BFD	1.339
L64-DA-12	8.50-11.50	MS91527-2BFH	1.505
L64-AA-16	9.0-16.0		1.323
L64-BA-16	9.0-16.0		1.489
L64-CA-16	9.0-16.0		1.323
L64-DA-16	9.0-16.0		1.489
L64-AA-20	10.0-20.0	MS91418-2AEL	1.391
L64-BA-20	10.0-20.0	MS91418-2AES	1.557
L64-CA-20	10.0-20.0	MS91527-2AED	1.391
L64-DA-20	10.0-20.0	MS91527-2AEH	1.557
L64-AA-20	11.48-15.53	MS91418-2BGL	1.366
L64-BA-20	11.48-15.53	MS91418-2BGS	1.532
L64-CA-20	11.48-15.53	MS91527-2BGD	1.366
L64-DA-20	11.48-15.53	MS91527-2BGH	1.532
L64-BA-20	15.30-20.70	MS91418-2BHL	1.406
L64-DA-20	15.30-20.70	MS91527-2BHD	1.406
L64-AA-40	20.0-40.0		1.400
L64-BA-40	20.0-40.0		1.566
L64-CA-40	20.0-40.0		1.400
L64-DA-40	20.0-40.0		1.400

L-Mount Series (L21/L22/L44/L64)

Load Ranges & MS Designations

Load Range In Pounds	Military* Designation	Barry Type No.	Weight ounces	H dimension (to flange = .045")		
				Under Min rated load	Maximum extended [†]	Minimum compressed [†]
0.25 - 0.50	See Note	L44-AA-1/2	1 3/4	1.371	1.632	0.975
0.25 - 0.50	See Note	L44-BA-1/2	1 1/2	1.527	1.788	1.131
0.17 - 0.23	MS91418-1BAD MS91527-1BAD	L44-CA-1/2	1 3/4	1.395	1.594	0.937
0.17 - 0.23	MS91418-1BAS MS91527-1BAH	L44-BA-1/2	1 1/2	1.589	1.788	1.131
0.25 - 0.35	MS91418-1BBL MS91527-1BBD	L44-AA-1/2	1 3/4	1.392	1.632	0.975
0.25 - 0.35	MS91418-1BBS MS91527-1BBH	L44-BA-1/2	1 1/2	1.562	1.788	1.131
0.34 - 0.46	MS91418-1BCL MS91527-1BCD	L44-AA-1/2	1 3/4	1.347	1.632	0.975
0.34 - 0.46	MS91418-1BCS MS91527-1BCH	L44-BA-1/2	1 1/2	1.520	1.788	1.131
0.50 - 1.00	See Note	L44-AA-1	1 3/4	1.389	1.632	0.975
0.50 - 1.00	See Note	L44-BA-1	1 1/2	1.545	1.788	1.131
0.51 - 0.69	MS91418-1BDL MS91527-1BDD	L44-AA-1	1 3/4	1.395	1.632	0.975
0.51 - 0.69	MS91418-1BDS MS91527-1BDH	L44-BA-1	1 1/2	1.562	1.788	1.131
0.68 - 0.92	MS91418-1BEL MS91527-1BED	L44-AA-1	1 3/4	1.352	1.632	0.975
0.68 - 0.92	MS91418-1BES MS91527-1BEH	L44-BA-1	1 1/2	1.526	1.788	1.131
0.85 - 1.15	MS91418-1BFL MS91527-1BFD	L44-AA-1	1 3/4	1.342	1.632	0.975
0.85 - 1.15	MS91418-1BFS MS91527-1BFH	L44-BA-1	1 1/2	1.501	1.788	1.131
1.00 - 2.00	See Note	L44-AA-2	1 3/4	1.404	1.632	0.975
1.00 - 2.00	See Note	L44-BA-2	1 1/2	1.566	1.788	1.131
1.16 - 1.58	MS91418-1BGL MS91527-1BGD	L44-AA-2	1 3/4	1.376	1.632	0.975
1.16 - 1.58	MS91418-1BGS MS91527-1BGH	L44-BA-2	1 1/2	1.562	1.788	1.131
1.48 - 2.01	MS91418-1BHL MS91527-1BHD	L44-AA-2	1 3/4	1.335	1.632	0.975
1.48 - 2.01	MS91418-1BHS MS91527-1BHH	L44-BA-2	1 1/2	1.525	1.788	1.131
1.50 - 3.00	See Note	L44-AA-3	1 1/2	1.404	1.632	0.975
1.50 - 3.00	See Note	L44-BA-3	1 3/4	1.566	1.788	1.131
1.50 - 3.00	MS91418-1AAL MS91527-1AAD	L44-AA-3	1 1/2	1.404	1.632	0.975
1.50 - 3.00	MS91418-1AAS MS91527-1AAH	L44-BA-3	1 3/4	1.562	1.788	1.131
2.01 - 2.73	MS91418-1BJL MS91527-1BJD	L44-AA-3	1 1/2	1.346	1.632	0.975
2.01 - 2.73	MS91418-1BJS MS91527-1BJH	L44-BA-3	1 3/4	1.562	1.788	1.131
2.00 - 4.00	See Note	L44-AA-4	1 1/2	1.401	1.632	0.975
2.00 - 4.00	See Note	L44-BA-4	1 3/4	1.557	1.788	1.131
2.76 - 3.73	MS91418-1BKL MS91527-1BKD	L44-AA-4	1 1/2	1.349	1.632	0.975
2.76 - 3.73	MS91418-1BKS MS91527-1BKH	L44-BA-4	1 3/4	1.524	1.788	1.131
2.50 - 5.00	See Note	L44-AA-5	1 1/2	1.393	1.632	0.975
2.50 - 5.00	See Note	L44-BA-5	1 3/4	1.549	1.788	1.131
2.50 - 5.50	MS91418-1ABL MS91527-1ABD	L44-AA-5	1 1/2	1.393	1.632	0.975
2.50 - 5.50	MS91418-1ABS MS91527-1ABH	L44-BA-5	1 3/4	1.562	1.788	1.131
3.61 - 4.89	MS91418-1BLL MS91527-1BLD	L44-AA-5	1 1/2	1.338	1.632	0.975
3.61 - 4.89	MS91418-1BLS MS91527-1BLH	L44-BA-5	1 3/4	1.523	1.788	1.131
5.00 - 10.00	See Note	L44-AA-10	1 1/2	1.395	1.632	0.975
5.00 - 10.00	See Note	L44-BA-10	1 3/4	1.551	1.788	1.131
4.89 - 6.61	MS91418-1BML MS91527-1BMD	L44-AA-10	1 1/2	1.399	1.632	0.975
4.89 - 6.61	MS91418-1BMS MS91527-1BMH	L44-BA-10	1 3/4	1.562	1.788	1.131
6.58 - 8.91	MS91418-1BNL MS91527-1BND	L44-AA-10	1 1/2	1.379	1.632	0.975
6.58 - 8.91	MS91418-1BNS MS91527-1BNH	L44-BA-10	1 3/4	1.535	1.788	1.131
8.50 - 11.50	MS91418-1BOL MS91527-1BOD	L44-AA-10	1 1/2	1.343	1.632	0.975
8.50 - 11.50	MS91418-1BOS MS91527-1BOH	L44-BA-10	1 3/4	1.501	1.788	1.131

NOTE: All standard L44 Barrymounts have a 2-to-1 load range to meet performance requirements of Spec. MIL-C-172C and are designated -AA and -BA in table above. Other designations listed above are designed to meet Class B requirements of Spec. MIL-C-172C for specified load rating ($\pm 15\%$).
[†] Parts will not be stamped with military designation unless specifically requested.
^{*} Under 15-times maximum rated load.